

COUNTY OF ULSTER

PATRICK K. RYAN

County Executive



ULSTER COUNTY PURCHASING DEPARTMENT

ED JORDAN

Director of Purchasing

CONTRACT AWARD INFORMATION

Title: ROAD MATERIALS

BID NUMBER: RFB-UC20-001

Contract Period: APRIL 1, 2020 – MARCH 31, 2021

Authorized Users: ALL

View Specifications at: <http://www.empirestatebidsystem.com/>

Submit Inquiries to:

If you intend to Piggyback off of this bid please contact Buyer first:

Name: MICHAEL MAPHIS

Phone: 845-340-3999

Fax: 845-340-3434

Email: mmap@co.ulster.ny.us

BID DESCRIPTION

The purpose of this bid is to establish a price for the purchase of various types of sand, stone, concrete and asphalt road materials **as needed** by the Ulster County Department of Public Works and other political subdivisions as authorized by law.

VENDOR LIST FOR 2020 SEASON

209 Sand & Gravel LLC, Napanoch
299 Main Street
Woodbourne, NY 12788
Contact: Bob Scheinman
Ph: 845-434-6628
Fax: 845-434-1655

Callanan Industries, Inc.
1245 Kings Road
PO Box 15097
Albany, NY 12212-5097
Contact: Jason Ilgner
Ph: 845-204-5178
Fax: 518-381-6775

<p>Cranesville Block Co. and Eastern Materials LLC 1250 Riverfront Center Amsterdam, NY 12010 Contact: Joe or John Tesiero Ph: 518-684-6007 Fax: 518-684-0127</p>	<p>Peckham Materials Corp. 763 Schoharie Turnpike Athens, NY 12015 Contact: Rick Rosa Ph: 518-945-1120 Fax: 518-945-1298</p>
<p>E. Tetz & Sons, Inc. 130 Crotty Road Middletown, NY 10941 Contact: Denise Tetz Ph: 845-692-4486 Fax: 845-692-6838</p>	<p>Mombaccus Excavating Inc. 710 Cherrytown Rd. Kerhonkson, NY 12446 Contact: Keith Kortright Ph: 845-626-0903 / 845-706-8566 Fax: 845-626-8147</p>
<p>Morlyn Asphalt Corp. 420 Bernas Rd Cochecton, NY 12726 Contact: Luke Bernas Ph: 845-932-7815 Fax: 845-932-8139</p>	<p>Morton Salt, Inc. 444 West Lake St., Suite 300 Chicago, Il 60606 Contact: Anthony Patton Ph: 855-665-4540</p>
<p>Northeast Solite Corp 962 Kings Highway-PO Box 437 Mt. Marion, NY 12456 Contact: Mike Weeks Ph: 845-246-9571 Fax: 845-246-2619</p>	<p>A. Collarusso & Son, Inc. 91 Newman Rd. PO BOX 302 Hudson, NY 12534 Conact: J.R.Heffner Ph: 518-828-3218</p>
<p>Eastern Materials 1250 Riverfront Center Amsterdam, NY 12010 Contact: Joe Tesiero Ph: 518-684-6007</p>	<p>Grosso Materials 90 Collabar Rd. Montgomery, NY 12549 Contact: Angela Grosso Ph: 845-361-5211</p>
<p>Red Wing Properties PO BOX 408 Stormville, NY 12582 Contact: Frank Doherty Jr. Ph: 845-231-2224</p>	

39.0 **SECTION A – PICKUP AT VENDOR’S STOCKYARD**

Ulster County Sections are for purposes of determining the County's **transportation costs** that will be added to the bid price offered to determine the most economical vendor to receive the Award. This cost will be calculated using the formula below and will be added to the bid price offered to determine the TOTAL COST to haul the materials. Each bid price will be individually calculated for each of the 5 Sections listed in order to determine the TOTAL COST for Award purposes. The BID WILL BE AWARDED BY ITEM, BY SECTION, to a single vendor for each product commodity that is low bid with the transportation factor added.

The transportation costs will be calculated by the County of Ulster using the most reasonable round trip, truck route from the Vendor’s Stockyard to a County owned highway facility in each Section or to an Ulster County job site. The transportation costs will be calculated by the County of Ulster based on an average truck load of ten tons. The calculation will use **\$2.60/round trip mile (per truckload)** multiplied by the appropriate number of round trip miles and then divided by 10 to estimate the cost, per ton, to transport each ton of material. These mileage calculations are determined by Ulster County and are final.

Example Calculation: Item name: #1 Stone, ID #190 (picked up at Vendor’s Stockyard)

Distance from vendor to delivery point - 15 miles (round trip equals 30 miles)

\$4.00/ton	Bid Price/ton loaded at stockyard (vendors bid)
\$7.80/ton	30 miles x \$2.60/mile divided by 10 tons (average per truckload)
\$11.80/ton	Total Item Cost/ton to use for the basis of the Award

All purchases shall be made from the awarded vendor for that Section. Purchases outside a Section may be made if it is proven by the ordering agency that the total cost (including trucking costs) is lower than the awarded vendor's cost.

The Award for Asphalt items will also be given for the second and third lowest in each Section to accommodate the County if an excessive wait is projected that will affect completion of a particular project.

Bidders should bid all locations (Quarries, Plants & Facilities) where the required products are available. Vendors should note on their bid sheet the specific location of the plant or facility they are bidding. A SEPARATE BID SHEET SHALL BE SUBMITTED FOR EACH PRODUCT FOR EACH LOCATION LISTING THE EXACT STREET ADDRESS.

40.0 **SECTION B – DELIVERED PRICING**

Items in **SECTION B – DELIVERED PRICING** may be awarded individually for each item delivered to each of the 5 Sections based on the lowest responsive, responsible bid. The bid for each Section shall include delivery of the item to any point within that Section. Bidders with more than one stockyard location must submit a separate bid sheet for each location reflecting the pricing delivered from that location to each of the Sections. The bidder must state individual prices for all units bid.

The price invoiced shall be the net price as bid by the awarded vendor. **No surcharges, fuel costs, prices escalations, or other cost adjustments not specifically permitted in these specifications will be allowed. All invoices must indicate the applicable UC Bid number, the Section where the items were delivered to and an accurate description of the**

product that was supplied. Failure to properly document each invoice may cause a delay in payment.

Bidders should bid all locations (Quarries, Plants & Facilities) where the required products are available. Vendors should note on their bid sheet the specific location of the plant or facility they are bidding. A SEPARATE BID SHEET SHALL BE SUBMITTED FOR EACH PRODUCT FOR EACH LOCATION LISTING THE EXACT STREET ADDRESS.

41.0 PRICE ADJUSTMENT FOR HOT ASPHALT PRODUCTS

Price Escalation and De-escalation will be allowed only on the hot asphalt products. **When a Price Adjustment is claimed on an invoice, that invoice must show the current Average Posted Price as well as the base Average Posted Price used in this specification and document the math used to determine the Adjustment that is being claimed. Failure to properly document each invoice may cause a delay in payment.**

The Price Adjustment will be based on the Average Posted Prices for Asphalt (Performance Graded Binder) per US ton as reported by the NYS DOT. This Average Posted Price is available on the DOT WEBSITE by searching for “fuel, asphalt & steel price adjustments” at <https://www.dot.ny.gov/main/business-center/contractors/construction-division/fuel-asphalt-steel-price-adjustments>

*The Base Average Posted Price for all asphalt prices submitted on this bid, and for all contracts that result from this bid, will be the price posted by the NYS DOT for **November 2019 which is \$521/US ton.***

The NYS DOT determines new Average Posted Prices for Asphalt each month. It should be understood that price adjustments, in accordance with the formula below, would be effective on purchases made on and after the first day of the following month. In no event will a price adjustment be effected unless the change amounts to more than \$.10 per ton. All price adjustments will be computed to two decimal places. Any and all price revisions allowed by this contract shall be calculated and applied to the original Unit Price per US Ton that was bid.

Any introduction or withdrawal of a temporary voluntary allowance, terminal operator’s allowance or other discount offered to the trade in general from the posted price of asphalt will be considered, for purposes of price adjustment, as a change in the posted price.

Formula:

The Unit Price per **US ton** of asphalt purchased under these Specifications will be adjusted, by Item, in accordance with the following formula:

The Price Adjustment equals the New Average Posted Price minus the Base Average Posted Price multiplied by the Total Percent % Liquid Asphalt in each product (as indicated below).

Sample Calculation:

If the new average posted price is established at \$600 per US ton and if the Base Average Posted Price for this bid is **\$521/ton** and we are adjusting the Unit Price per Ton of Hot Mix Asphalt Type 7 (**7.85%**), the calculation would be as follows:

$$(600.00 - 521.00) \times .0785 = (+) \$6.20/\text{Ton of Asphalt Type 7}$$

The Awarded vendor will be allowed to add **\$6.20** to his bid price per ton when invoicing Asphalt Type 7.

The total percentage of liquid asphalt is indicated below for each of these Specifications:

NYS DOT ITEM #	DESCRIPTION	% LIQUID ASPHALT
402.378901	37.5 F9 Base Course HMA	5.5
402.258901	25 F9 Binder Course HMA,	5.5
402.198901	19 F9 Binder Course HMA,	5.9
402.128201	12.5 F2 Top Course HMA,	6.5
402.098201	9.5 F2 Top Course HMA,	7.2
402.03830118	Miscellaneous Patching F3 HMA	6.5

UC ITEM #	DESCRIPTION	% LIQUID ASPHALT
1150	Hot Mix Asphalt, Type 7	7.85

All Hot Mix Asphalt shall meet NYS Standard DOT specifications dated January 2, 1995

42.0 PRICE ADJUSTMENT FOR FUEL PRODUCTS USED IN DELIVERED PRICING

Price Escalation and De-escalation will be allowed as a “surcharge” on the invoice for fuel products used to deliver contract materials to Ulster County. **When a Price Adjustment is claimed on an invoice, that invoice must show the current Average Posted Price as well as the base Average Posted Price used in this specification and document the math used to determine the Adjustment that is being claimed. Failure to properly document each invoice may cause a delay in payment.**

The Price Adjustment will be based on the US Energy Information Administration (EIA) price per US gallon for Ultra Low sulfur Diesel Fuel for the New England States. This Weekly Average Posted Price is available on the EIA Website at <http://www.eia.gov/> by clicking on “Sources/Petroleum and other liquids” and then “Data” and “Prices”. Choose the “Weekly Retail Gasoline and on-highway Diesel Prices” and select “New England (PADD 1A).

The **Base Average Posted Price** for any fuel adjustments (surcharges) for all contracts that result from this bid will be the price posted by the US EIA for **the week of December 9th, 2019 for Ultra Low Sulfur Diesel Fuel for the New England States which is \$3.085, as shown in the chart below.**

The US EIA determines new Average Posted Prices for Fuel each week. It should be understood that price adjustments (surcharges) for fuel, in accordance with the chart below, would be effective on deliveries made on and after the first day of the week of the posting. **Fuel surcharges will not be allowed until the Average Posted Price changes more than \$0.50 above or below the base price.** Once the posted price leaves the Base Price Range shown on the following chart each additional change exceeding \$0.25 will result in a \$4.00 surcharge **per delivery** as shown. i.e. If the Average Posted Price is \$3.586/gallon then a

surcharge of \$4.00 per delivery may be applied as the cost has increased past the \$3.585 threshold (see below).

Previous price history for diesel fuel is available at <http://www.eia.gov/petroleum/gasdiesel/> but can be hard to find. **Vendors that add the surcharge to their invoice are required to print the applicable EIA price page (as shown below) and submit it with their invoice to avoid confusion or delay in payment.**

WEEKLY EIA POSTED DIESEL PRICE	SURCHARGE ALLOWED PER DELIVERY
Under \$2.085	(\$12.00 CREDIT)
Under \$2.335	(\$8.00 CREDIT)
Under \$2.585	(\$4.00 CREDIT)
\$2.585 - \$3.585	BASE RANGE
Over \$3.585	\$4.00
Over \$3.835	\$8.00
Over \$4.085	\$12.00
Over \$4.335	\$16.00
Over \$4.585	\$20.00
Over \$4.835	\$24.00
Over \$5.085	\$28.00

Weekly Retail Gasoline and Diesel Prices

(Dollars per Gallon, Including Taxes)

Area: Period:

Show Data By:		GraphClear	11/04/19	11/11/19	11/18/19	11/25/19	12/02/19	12/09/19	View History
<input checked="" type="radio"/> Product	<input type="radio"/> Area								
Gasoline - All Grades	<input type="checkbox"/>		2.605	2.612	2.605	2.608	2.610	2.600	1993-2019
All Grades - Conventional Areas	<input type="checkbox"/>		2.587	2.575	2.579	2.586	2.597	2.571	1994-2019
All Grades - Reformulated Areas	<input type="checkbox"/>		2.608	2.616	2.609	2.611	2.612	2.603	1994-2019
Regular	<input type="checkbox"/>		2.530	2.535	2.530	2.532	2.537	2.523	1993-2019
Conventional Areas	<input type="checkbox"/>		2.542	2.531	2.535	2.543	2.555	2.527	1993-2019
Reformulated Areas	<input type="checkbox"/>		2.528	2.535	2.529	2.530	2.534	2.522	1994-2019
Midgrade	<input type="checkbox"/>		2.861	2.875	2.865	2.867	2.854	2.859	1994-2019
Conventional Areas	<input type="checkbox"/>		2.925	2.909	2.908	2.898	2.885	2.876	1994-2019
Reformulated Areas	<input type="checkbox"/>		2.856	2.873	2.862	2.865	2.852	2.857	1994-2019
Premium	<input type="checkbox"/>		3.070	3.087	3.068	3.085	3.066	3.079	1994-2019
Conventional Areas	<input type="checkbox"/>		3.060	3.042	3.043	3.048	3.055	3.047	1994-2019
Reformulated Areas	<input type="checkbox"/>		3.071	3.090	3.070	3.088	3.067	3.081	1994-2019

Diesel (On-Highway) - All Types	<input type="checkbox"/>	3.034	3.042	3.049	3.063	3.078	3.085	1997-2019
Ultra Low Sulfur (15 ppm and Under)	<input type="checkbox"/>	3.034	3.042	3.049	3.063	3.078	3.085	2007-2019

43.0 PRODUCT SPECIFICATIONS AND REQUIREMENTS

43.1 REDI-MIX CONCRETE

Redi-mix concrete. NYS DOT Requirements-Section 501. Price requested: Class A (approximately 3,500 psi) & Class E (approximately 5,000 psi) per yard. Minimum load to avoid short load charge is 5 yards. NYS DOT approved source or aggregate.

Extras such as fiber mesh, heat/winter mix, short load charge, charge for excessive wait time, etc will be considered non-contract items and the cost will be negotiated at the time the order is placed.

The Award for Redi-Mix concrete will also be given for the second and third lowest in each Section to accommodate the County if an excessive wait is projected at the Awarded vendor's plant that will affect completion of a particular project.

43.2 ROCK SALT

The bulk of the rock salt used by the Ulster County Department of Highway & Bridges will be purchased from the NYS Contract. This Bid will be primarily for use by the towns and other municipalities.

Material to be furnished will comply with or exceed the specs of the NYS DOT in bulk. Material shall not contain over 1 1/2% of moisture by weight. Bulk salt shall be properly stored and protected from precipitation until delivery. A certified weight receipt shall support each delivery of bulk salt.

The supplier must maintain a stockyard within a radius of 50 miles of the City of Kingston with bulk salt in sufficient quantities to insure its availability under ordinary conditions. At least 5000 tons must be on site and available for delivery within Ulster County. Supplier must indicate the bulk price per ton, FOB said stockyard, loaded on County, Town or other entity vehicle.

The minimum order for pickup by the County, Town or other user will be 10 tons.

The minimum order for delivery will be 22 ton full truckloads.

43.3 STONE ITEMS #1A, #1ST, AND #1 & #2 MIXED - MUST BE WASHED

These stone items must be washed according to the specifications that follow. A description of the plant flow operation of the vendors washing process must be returned with the bid proposal. Stone must meet the following specifications:

MATERIAL

- a) Stone shall conform to the material requirements of NYS DOT Standard Specification Section 703-02 dated January 1, 2019.

b) All Stone Items in this bid shall consist of clean, durable, sharp-angled fragments of rock of uniform quality. The sizes of all stone used shall conform to the gradation requirements for the various sizes tabulated in Table 43.3-1 (below).

Table 43.3 - 1⁽¹⁾: Sizes of Stone											
<u>Size Designation</u>	<u>Screen Size</u>										
	4 in	3 in	2-1/2 in	2 in	1-1/2 in	1 in	1/2 in	1/4 in	1/8 in	# 80	#200
1A	-	-	-	-	-	-	100	90-100	0-15	-	0-1.0
1ST	-	-	-	-	-	-	100	0-15	-	-	0-1.0
1	-	-	-	-	-	100	90-100	0-15	-	-	0-1.0
2	-	-	-	-	100	90-100	0-15	-	-	-	0-1.0

⁽¹⁾Percentage by weight passing the following square openings.

WASHING PROCESS - FOR ALL SIZES OF STONE

Stone shall be washed to remove any deleterious materials. In addition to the above sizing specs, special consideration must be given to excess adhesion of dust, clay, and silt to the finished product. The County will routinely test for required cleanliness at their discretion.

INSPECTION OF WASHING PROCESS - FOR ALL SIZES OF STONE

Ulster County reserves the right to inspect the washing process of stone material at any time. The County has the right, at any time, to obtain random samples for testing to determine sizing and surface cleanliness. ***The County also reserves the right to disqualify a bid award based on an unacceptable washing facility.***

43.4 #2 STONE, #3 STONE, #4 STONE, #4A STONE, FINE, LIGHT, MEDIUM, HEAVY STONE, ITEM No. 4, - WILL BE UNWASHED

Unwashed stone shall conform to Section 703-02 as per NYS DOT Standard Specs dated January 1, 2019.



#2 Stone, #3 Stone #3A Stone, #4 Stone, and #4A Stone are crushed stones and shall consist of clean, durable, sharp-angled fragments of rock of uniform quality. The sizes of all stone used shall conform to the gradation requirements for the various sizes tabulated in Table 43.5-1 (below).

Table 43.5 - 1⁽¹⁾: Sizes of Stone											
<u>Size Designation</u>	<u>Screen Size</u>										
	4 in	3 in	2-1/2 in	2 in	1-1/2 in	1 in	1/2 in	1/4 in	1/8 in	# 80	#200
2	-	-	-	-	100	90-100	0-15	-	-	-	0-1.0
3A	-	-	-	100	90-100	0-15	-	-	-	-	0-0.7
3	-	-	100	90-100	35-70	0-15	-	-	-	-	0-0.7
4A	-	100	90-100	-	0-20	-	-	-	-	-	0-0.7
4	100	90-100	-	0-15	-	-	-	-	-	-	0-0.7

⁽¹⁾Percentage by weight passing the following square openings.

Fine, Light, Medium, and Heavy Stone shall compose material consisting blasted or broken unweathered rock. The material shall have a gradation in accordance to Table 43.5-2: *Stone Filling Gradation* and Table 43.5-3: *Stone Filling Approximate Shape* (below).

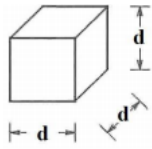
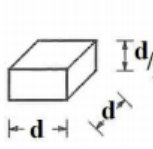
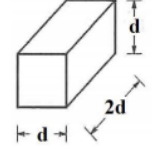
<u>Stone Filling Item</u>	<u>See Notes</u>	<u>Stone Size</u>	<u>Percent of Total by Weight</u>
Fine	2,3,4	Smaller than 8 in.	90-100
		Larger than 3 in.	50-100
		Smaller than No. 10 sieve	0-10
Light	2,3,4	Lighter than 100 lbs.	90-100
		Larger than 6 in.	50-100
		Smaller than 1/2 in.	0-10
Medium	2,4	Heavier than 100 lbs.	50-100
		Smaller than 4 in.	0-10
Heavy	2,4,5	Heavier than 600 lbs.	50-100
		Smaller than 6 in.	0-10

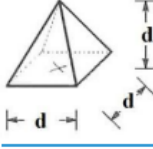
<u>Specified Weights and Sizes</u>					
600 lbs.	d = 18 in.	d = 23 in.	d = 15 in.	d = 23 in.	d = 27 in.
300 lbs.	d = 15 in.	d = 18 in.	d = 12 in.	d = 18 in.	d = 21 in.
150 lbs.	d = 12 in.	d = 15 in.	d = 9 in.	d = 15 in.	d = 17 in.
100 lbs.	d = 10 in.	d = 13 in.	d = 8 in.	d = 13 in.	d = 15 in.
d = 8 in.	50 lbs.	25 lbs.	100 lbs.	25 lbs.	16 lbs.
d = 6 in.	20 lbs.	10 lbs.	40 lbs.	10 lbs.	7 lbs.

Notes:

1. Stone sizes, other than weights, refer to the average of the maximum and minimum dimensions of a stone particle as estimated by the Engineer.
2. Materials shall contain less than 20% of stones with a ratio of maximum to minimum dimension greater than three.
3. Cobbles or gravel having at least one fractured face per particle are acceptable substitutes for stone under these items, provided that the soundness and gradation requirements are met.
4. Materials shall contain a sufficient amount of stones smaller than the average stone size to fill in the spaces between the larger stones.
5. Heavier gradings of this item may be required on some projects, in which case the requirements will be stated in the contract documents.

Item No. 4 shall be available in type 2 and type 4. The composition of type 2 furnished materials shall consist of stone. Type 4 furnished materials shall consist of stone, sand, and gravel. Materials must have gradation in accordance with Table 43.5-4: *Item No. 4 Subbase Gradation* (below).

<u>Sieve Size Designation</u>	<u>Percentage Passing by Weight</u>	
	<u>Type 2:</u>	<u>Type 4:</u>
4 in.	-	-
3 in.	-	-
2 in.	100	100

1/4 in.	25-60	30-65
No. 40	5-40	5-40
No. 200	0-10	0-10

43.5 SELECT FILL AND SELECT GRANULAR FILL

Select Fill will be composed of suitable, well graded material consisting of rock, stone, cobbles, or gravel. Select Fill material shall not have any particles larger than 3 ft. in maximum diameter. Of the portion passing through the 4 in. square sieve, the material shall have a gradation in accordance with Table 43.6-1: *Select Fill Gradation* (below).

Table 43.6-1: Select Fill Gradation	
<u>Sieve Size Designation</u>	<u>Percentage Passing by Weight</u>
No. 40	0-70
No. 200	0-15

Select Granular Fill will be composed of suitable, well graded material consisting of rock, stone, cobbles, or gravel. Select Granular Fill must have gradation in accordance to Table 43.6-2: *Select Granular Fill Gradation* (below).

Table 43.6-2: Select Granular Fill Gradation	
<u>Sieve Size Designation</u>	<u>Percentage Passing by Weight</u>
4 in.	100
No. 40	0-70
No. 200	0-15

43.6 RECTANGULAR QUARRIED STACKABLE BOULDERS

Rectangular quarried boulders shall be generally rectangular and flat in shape, suitable for stacking and placement such that they form a strong, stable, interlocking and generally flat surface when completed.

Boulders shall have a minimum weight of 4,000 lbs, maximum weight of 10,000 lbs, intermediate axis of 36 inches to 48 inches, and short axis of 12 inches to 24 inches, to within 25% of the desired dimensions. Measurements of the intermediate and short axes are illustrated below as the "B" and "C" axes respectively.

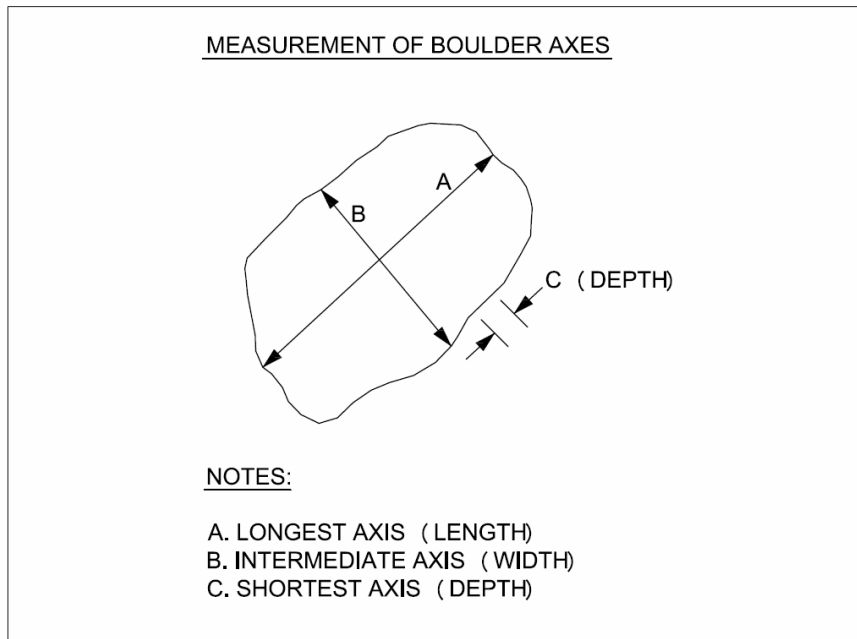

Boulders shall be of sufficient hardness to resist weathering, dense, sound and free from cracks, seams, and other defects which contribute to accelerated weathering. Limestone, sandstone, shales, and other porous or soft rocks will not be permitted for use.

43.7 TOPSOIL

Topsoil shall be free from refuse, material toxic or otherwise deleterious to plant growth, subsoil, sod clumps, seeds or other viable propagules of invasive plants, woody vegetation and stumps, roots, brush, refuse, stones, clay lumps, or similar objects. Construction and demolition debris as classified under 6 NYCRR Part 360, other than uncontaminated land clearing debris, shall not be used to manufacture or amend topsoil. Sod and herbaceous growth such as grass and non-invasive weeds need not be removed but shall be thoroughly broken up and mixed with the soil during handling or manufacturing operations. Topsoil must have a gradation in accordance to Table 43.8-Topsoil, a pH between 5.5 – 7.6, and the organic content shall be not less than 6% or more than 12%.

<u>Table 43.8-1: Topsoil Gradation</u>	
<u>Sieve Size</u>	<u>Percent Passing by Weight</u>
1 inch	100
No. 10	90 to 100
No. 40	45 to 80
No. 200	25 to 70
2 Micron	5 to 35

**43.8 ABRASIVE SAND, WASHED
ABRASIVE SAND, SCREENED**

ABRASIVE SCREENINGS, WASHED
ABRASIVE SCREENINGS, SCREENED
ABRASIVE STONE DUST

Sand and screenings for abrasives shall consist of clean, hard, durable, uncoated particles, free from lumps of clay and all deleterious substances. The sand and screenings may be determined to be unacceptable for abrasives if it contains more than 10 percent by volume of loam or silt. All material furnished under this specification shall be in conformance with the current New York State Department of Transportation Standard Specifications for Construction and Materials and all Addenda thereto; specifically, as set forth in Section 703 - Aggregates, Sub-Section 703-01 Fine Aggregate. Abrasive sand and screening should be in conformance with Gradation A (Table 43.9-1) or Gradation B (Table 43.9-2) listed below, while abrasive stone dust should conform to Gradation C (Table 43.9-3).

Table 43.9-1: Abrasive Gradation A	
<u>Sieve Size</u>	<u>Percent Passing by Weight</u>
1/2"	100
3/8"	100
#4	80-100
#50	0-18
#200	0-3

Table 43.9-2: Abrasive Gradation B	
<u>Sieve Size</u>	<u>Percent Passing by Weight</u>
1/2"	100
3/8"	100
#4	80-100
#50	0-25
#200	0-5

Table 43.9-3: Abrasice Gradation C	
<u>Sieve Size</u>	<u>Percent Passing by Weight</u>
1/2"	100
3/8"	95-100
#4	20-90
#8	10-60
#30	0-15

Bid prices shall be price per ton only. Any variation will not be accepted.

43.9 ABRASIVE SAND, SCREENED AND MIXED WITH COUNTY SUPPLIED SALT
ABRASIVE SCREENINGS, SCREENED AND MIXED WITH COUNTY SUPPLIED SALT

NOTE! - VENDORS THAT BID THESE PRODUCTS MUST HAVE THE ABILITY TO MIX ABRASIVES WITH SALT.

The Vendor must provide various abrasive materials and have the ABILITY TO MIX SAME with rock salt at a ratio of three parts sand to one part salt. Rock salt will be provided and delivered by the County to the vendor's stockyard. Price offered will be per ton of abrasive material provided by the vendor and include proper mixing with the County provided salt.

Sand and screenings for abrasives shall consist of clean, hard, durable, uncoated particles, free from lumps of clay and all deleterious substances. The sand and screenings may be determined to be unacceptable for abrasives if it contains more than 10 percent by volume of loam or silt. Sand, screenings, and stone dust for abrasives shall be in accordance with the gradations listed in Table 43.9-1, Table 43.9-2 and Table 43.9-3 located in Section 43.9 in this document.

Bid prices shall be price per ton only

Sand and salt mix is to be made available for pickup by Ulster County trucks operated by authorized County personnel only. These products are not available to other towns or municipalities.

43.10 HOT MIX ASPHALT

Ulster County is seeking the following Hot Mix Asphalt products:

- NYSDOT Item 402.098201; 9.5 mm F2 Top Course HMA
- NYSDOT Item 402.128201; 12.5 mm F2 Top Course HMA
- NYSDOT Item 402.198901; 19 mm F9 Binder Course HMA
- NYSDOT Item 402.258901; 25 mm F9 Binder Course HMA
- NYSDOT Item 403.378901; 37.5 mm F9 Base Course HMA
- NYSDOT Item 402.0380118; Miscellaneous Patching F3 HMA
- UC Item Type 7 top mix– No RAP

All Hot Mix Asphalt shall meet most current NYS DOT Standard Specifications (Section 400).

43.11 COMMERCIAL RECYLED ASPHALT PRODUCT / BLENDED SUBBASE

This item shall consist of a High Friction Limestone processed through an asphalt plant and/or milled from existing roadways and then through a screen plant to have a gradation of ½" Minus with an asphalt content of 4%.

A

COUNTY OF ULSTER

BID #UC20-001

**2020 PICKUP DATA
Calculation sheet**

**TERM 4/1/2020-
3/31/2021**

MILEAGE CALCULATION SPREADSHEET

<u>LOW</u>	<u>ZONE</u>	<u>ITEM ID#</u>	<u>ITEM DESCRIPTION</u>	<u>VENDOR</u>	<u>BID PRICE P/U AT QUARRY Per Ton</u>
		1 160	ROCK SALT- 10 TON MIN.	A. Colarusso	\$80.00
		2 160	ROCK SALT- 10 TON MIN.	A. Colarusso	\$80.00
		3 160	ROCK SALT- 10 TON MIN.	A. Colarusso	\$80.00
		4 160	ROCK SALT- 10 TON MIN.	A. Colarusso	\$80.00
		5 160	ROCK SALT- 10 TON MIN.	A. Colarusso	\$80.00
		1 190	#1 STONE - WASHED	Callanan East Kingston	\$14.00
		2 190	#1 STONE - WASHED	Grosso Materials	\$11.50
		3 190	#1 STONE - WASHED	Callanan East Kingston	\$14.00
		4 190	#1 STONE - WASHED	Grosso Materials	\$11.50
		5 190	#1 STONE - WASHED	Callanan Monticello	\$13.00
		1 280	#1ST STONE - WASHED	Peckham	\$13.90
		2 280	#1ST STONE - WASHED	Grosso Materials	\$11.00
		3 280	#1ST STONE - WASHED	Peckham	\$13.90
		4 280	#1ST STONE - WASHED	Grosso Materials	\$11.00
		5 280	#1ST STONE - WASHED	Callanan Monticello	\$14.10
		1 310	#1A STONE - WASHED	Callanan East Kingston	\$23.00
		2 310	#1A STONE - WASHED	Callanan East Kingston	\$23.00
		3 310	#1A STONE - WASHED	Callanan East Kingston	\$23.00
		4 310	#1A STONE - WASHED	Callanan East Kingston	\$23.00
		5 310	#1A STONE - WASHED	E. Tetz Mongaup Valley	\$18.50
		1 340	# 1 & # 2 MIXED STONE - WASHED	Callanan East Kingston	\$12.85
		2 340	# 1 & # 2 MIXED STONE - WASHED	Callanan East Kingston	\$12.85
		3 340	# 1 & # 2 MIXED STONE - WASHED	Callanan East Kingston	\$12.85
		4 340	# 1 & # 2 MIXED STONE - WASHED	Callanan East Kingston	\$12.85
		5 340	# 1 & # 2 MIXED STONE - WASHED	Callanan Monticello	\$12.90
		1 370	#2 STONE	Eastern Materials Jockey Hill	\$12.00
		2 370	#2 STONE	Grosso Materials	\$12.50
		3 370	#2 STONE	Callanan East Kingston	\$12.85
		4 370	#2 STONE	Mombaccus	\$12.00
		5 370	#2 STONE	Mombaccus	\$12.00
		1 380	#3A STONE (MIX OF #2 & #3)	Eastern Materials Jockey Hill	\$13.00
		2 380	#3A STONE (MIX OF #2 & #3)	Callanan East Kingston	\$12.85
		3 380	#3A STONE (MIX OF #2 & #3)	Callanan East Kingston	\$12.85
		4 380	#3A STONE (MIX OF #2 & #3)	Mombaccus	\$14.00
		5 380	#3A STONE (MIX OF #2 & #3)	Mombaccus	\$14.00
		1 400	#3 STONE	Eastern Materials Jockey Hill	\$13.00
		2 400	#3 STONE	Grosso Materials	\$13.50
		3 400	#3 STONE	Eastern Materials Jockey Hill	\$13.00
		4 400	#3 STONE	Mombaccus	\$12.00
		5 400	#3 STONE	Mombaccus	\$12.00
		1 410	#4A STONE	Eastern Materials Jockey Hill	\$16.00

2	410	#4A STONE	Mombaccus	\$16.00
3	410	#4A STONE	Eastern Materials Jockey Hill	\$16.00
4	410	#4A STONE	Mombaccus	\$16.00
5	410	#4A STONE	Mombaccus	\$16.00
1	420	#4 STONE	Eastern Materials Jockey Hill	\$16.00
2	420	#4 STONE	Callanan East Kingston	\$14.50
3	420	#4 STONE	Callanan East Kingston	\$14.50
4	420	#4 STONE	Mombaccus	\$16.00
5	420	#4 STONE	Mombaccus	\$16.00
1	430	ITEM NO. 4	Eastern Materials Jockey Hill	\$9.75
2	430	ITEM NO. 4	Mombaccus	\$9.50
3	430	ITEM NO. 4	Callanan East Kingston	\$10.25
4	430	ITEM NO. 4	Mombaccus	\$9.50
5	430	ITEM NO. 4	209 Sand & Gravel	\$15.75
1	450	FINE STONE	Eastern Materials Jockey Hill	\$15.00
2	450	FINE STONE	Callanan East Kingston	\$14.50
3	450	FINE STONE	Callanan East Kingston	\$14.50
4	450	FINE STONE	Mombaccus	\$16.00
5	450	FINE STONE	Mombaccus	\$16.00
1	460	LIGHT STONE	Mombaccus	\$14.00
2	460	LIGHT STONE	Mombaccus	\$14.00
3	460	LIGHT STONE	Callanan East Kingston	\$16.25
4	460	LIGHT STONE	Mombaccus	\$14.00
5	460	LIGHT STONE	Mombaccus	\$14.00
1	490	MEDIUM STONE	Eastern Materials Jockey Hill	\$16.00
2	490	MEDIUM STONE	Mombaccus	\$17.00
3	490	MEDIUM STONE	Eastern Materials Jockey Hill	\$16.00
4	490	MEDIUM STONE	Mombaccus	\$17.00
5	490	MEDIUM STONE	Mombaccus	\$17.00
1	520	HEAVY STONE	Eastern Materials Jockey Hill	\$16.00
2	520	HEAVY STONE	Callanan East Kingston	\$19.50
3	520	HEAVY STONE	Eastern Materials Jockey Hill	\$16.00
4	520	HEAVY STONE	Mombaccus	\$20.00
5	520	HEAVY STONE	Mombaccus	\$20.00
1	550	SELECT FILL	Mombaccus	\$5.00
2	550	SELECT FILL	Mombaccus	\$5.00
3	550	SELECT FILL	Callanan East Kingston	\$9.25
4	550	SELECT FILL	Mombaccus	\$5.00
5	550	SELECT FILL	Mombaccus	\$5.00
1	580	SELECT GRANULAR FILL	Mombaccus	\$5.00
2	580	SELECT GRANULAR FILL	Mombaccus	\$5.00
3	580	SELECT GRANULAR FILL	Callanan East Kingston	\$9.25
4	580	SELECT GRANULAR FILL	Mombaccus	\$5.00
5	580	SELECT GRANULAR FILL	Mombaccus	\$5.00
1	1210	RECTANGULAR QUARRIED BOULDERS	Peckham	\$19.60
2	1210	RECTANGULAR QUARRIED BOULDERS	Peckham	\$19.60
3	1210	RECTANGULAR QUARRIED BOULDERS	Peckham	\$19.60
4	1210	RECTANGULAR QUARRIED BOULDERS	Callanan Monticello	\$24.00
5	1210	RECTANGULAR QUARRIED BOULDERS	Callanan Monticello	\$24.00
1	790	TOPSOIL	209 Sand & Gravel	\$25.50
2	790	TOPSOIL	209 Sand & Gravel	\$25.50
3	790	TOPSOIL	209 Sand & Gravel	\$25.50

4	790	TOPSOIL	209 Sand & Gravel	\$25.50
5	790	TOPSOIL	209 Sand & Gravel	\$25.50
1	800	ABRASIVE SAND, WASHED	Peckham	\$11.00
2	800	ABRASIVE SAND, WASHED	Peckham	\$11.00
3	800	ABRASIVE SAND, WASHED	Peckham	\$11.00
4	800	ABRASIVE SAND, WASHED	Peckham	\$11.00
5	800	ABRASIVE SAND, WASHED	E. Tetz Mongaup Valley	\$21.00
1	700	ABRASIVE SAND, SCREENED	Mombaccus	\$9.50
2	700	ABRASIVE SAND, SCREENED	209 Sand & Gravel	\$6.50
3	700	ABRASIVE SAND, SCREENED	209 Sand & Gravel	\$6.50
4	700	ABRASIVE SAND, SCREENED	209 Sand & Gravel	\$6.50
5	700	ABRASIVE SAND, SCREENED	209 Sand & Gravel	\$6.50
1	1240	ABRASIVE SCREENINGS, WASHED	Eastern Materials Jockey Hill	\$13.35
2	1240	ABRASIVE SCREENINGS, WASHED	Callanan East Kingston	\$14.75
3	1240	ABRASIVE SCREENINGS, WASHED	Callanan East Kingston	\$14.75
4	1240	ABRASIVE SCREENINGS, WASHED	Eastern Materials Jockey Hill	\$14.75
5	1240	ABRASIVE SCREENINGS, WASHED	Callanan Monticello	\$12.00
1	760	ABRASIVE SCREENINGS, SCREENED	Northeast Solite	\$5.50
2	760	ABRASIVE SCREENINGS, SCREENED	Northeast Solite	\$5.50
3	760	ABRASIVE SCREENINGS, SCREENED	Northeast Solite	\$5.50
4	760	ABRASIVE SCREENINGS, SCREENED	Mombaccus	\$12.00
5	760	ABRASIVE SCREENINGS, SCREENED	Mombaccus	\$12.00
1	810	ABRASIVE STONE DUST	Eastern Materials Jockey Hill	\$13.00
2	810	ABRASIVE STONE DUST	Callanan East Kingston	\$13.75
3	810	ABRASIVE STONE DUST	Callanan East Kingston	\$13.75
4	810	ABRASIVE STONE DUST	Callanan Monticello	\$6.50
5	810	ABRASIVE STONE DUST	Callanan Monticello	\$6.50
1	820	ABRASIVE SAND, SCREENED, MIXED W/COUNTY SUPPLIED SALT	Mombaccus	\$12.00
2	820	ABRASIVE SAND, SCREENED, MIXED W/COUNTY SUPPLIED SALT	Mombaccus	\$12.00
3	820	ABRASIVE SAND, SCREENED, MIXED W/COUNTY SUPPLIED SALT	Mombaccus	\$12.00
4	820	ABRASIVE SAND, SCREENED, MIXED W/COUNTY SUPPLIED SALT	Mombaccus	\$12.00
5	820	ABRASIVE SAND, SCREENED, MIXED W/COUNTY SUPPLIED SALT	Mombaccus	\$12.00
1	880	ABRASIVE SCREENINGS, SCREENED, MIXED W/COUNTY SUPPLIED SALT	Mombaccus	\$12.00

	2	880	ABRASIVE SCREENINGS, SCREENED, MIXED W/COUNTY SUPPLIED SALT	Mombaccus	\$12.00
	3	880	ABRASIVE SCREENINGS, SCREENED, MIXED W/COUNTY SUPPLIED SALT	Mombaccus	\$12.00
	4	880	ABRASIVE SCREENINGS, SCREENED, MIXED W/COUNTY SUPPLIED SALT	Mombaccus	\$12.00
	5	880	ABRASIVE SCREENINGS, SCREENED, MIXED W/COUNTY SUPPLIED SALT	Mombaccus	\$12.00
	1	890	COMMERCIAL RECYCLED ASPHALT PRODUCT / BLENDED SUBBASE	Callanan East Kingston	\$8.50
	2	890	COMMERCIAL RECYCLED ASPHALT PRODUCT / BLENDED SUBBASE	Callanan East Kingston	\$8.50
	3	890	COMMERCIAL RECYCLED ASPHALT PRODUCT / BLENDED SUBBASE	Callanan East Kingston	\$8.50
	4	890	COMMERCIAL RECYCLED ASPHALT PRODUCT / BLENDED SUBBASE	Callanan East Kingston	\$8.50
	5	890	COMMERCIAL RECYCLED ASPHALT PRODUCT / BLENDED SUBBASE	Callanan East Kingston	\$8.50
1st	1	1150	HOT MIX ASPHALT, NYS DOT TYPE 7 TOP COURSE	Eastern Materials Rt. 28	\$57.50
2nd	1	1150	HOT MIX ASPHALT, NYS DOT TYPE 7 TOP COURSE	Callanan East Kingston	\$60.50
3rd	1	1150	HOT MIX ASPHALT, NYS DOT TYPE 7 TOP COURSE	Peckham	\$57.00
1st	2	1150	HOT MIX ASPHALT, NYS DOT TYPE 7 TOP COURSE	Callanan East Kingston	\$60.50
2nd	2	1150	HOT MIX ASPHALT, NYS DOT TYPE 7 TOP COURSE	Peckham	\$57.00
3rd	2	1150	HOT MIX ASPHALT, NYS DOT TYPE 7 TOP COURSE	Eastern Materials Rt. 28	\$57.50
1st	3	1150	HOT MIX ASPHALT, NYS DOT TYPE 7 TOP COURSE	Callanan East Kingston	\$60.50
2nd	3	1150	HOT MIX ASPHALT, NYS DOT TYPE 7 TOP COURSE	Peckham	\$57.00
3rd	3	1150	HOT MIX ASPHALT, NYS DOT TYPE 7 TOP COURSE	Eastern Materials Rt. 28	\$57.50
1st	4	1150	HOT MIX ASPHALT, NYS DOT TYPE 7 TOP COURSE	Callanan East Kingston	\$60.50
2nd	4	1150	HOT MIX ASPHALT, NYS DOT TYPE 7 TOP COURSE	Morlyn Asphalt	\$60.00
3rd	4	1150	HOT MIX ASPHALT, NYS DOT TYPE 7 TOP COURSE	Eastern Materials Rt. 28	\$57.50
1st	5	1150	HOT MIX ASPHALT, NYS DOT TYPE 7 TOP COURSE	Eastern Materials Rt. 28	\$57.50
2nd	5	1150	HOT MIX ASPHALT, NYS DOT TYPE 7 TOP COURSE	Morlyn Asphalt	\$60.00
3rd	5	1150	HOT MIX ASPHALT, NYS DOT TYPE 7 TOP COURSE	Callanan Monticello	\$60.50

1st	1	1280	HOT MIX ASPHALT, 402.378901 37.5 F9 BASE COURSE	Eastern Materials Rt. 28	\$53.00
2nd	1	1280	HOT MIX ASPHALT, 402.378901 37.5 F9 BASE COURSE	Callanan East Kingston	\$53.25
3rd	1	1280	HOT MIX ASPHALT, 402.378901 37.5 F9 BASE COURSE	Peckham	\$51.00
1st	2	1280	HOT MIX ASPHALT, 402.378901 37.5 F9 BASE COURSE	Callanan East Kingston	\$53.25
2nd	2	1280	HOT MIX ASPHALT, 402.378901 37.5 F9 BASE COURSE	Peckham	\$51.00
3rd	2	1280	HOT MIX ASPHALT, 402.378901 37.5 F9 BASE COURSE	Morlyn Asphalt	\$51.00
1st	3	1280	HOT MIX ASPHALT, 402.378901 37.5 F9 BASE COURSE	Callanan East Kingston	\$53.25
2nd	3	1280	HOT MIX ASPHALT, 402.378901 37.5 F9 BASE COURSE	Peckham	\$51.00
3rd	3	1280	HOT MIX ASPHALT, 402.378901 37.5 F9 BASE COURSE	Eastern Materials Rt. 28	\$53.00
1st	4	1280	HOT MIX ASPHALT, 402.378901 37.5 F9 BASE COURSE	Morlyn Asphalt	\$51.00
2nd	4	1280	HOT MIX ASPHALT, 402.378901 37.5 F9 BASE COURSE	Callanan East Kingston	\$53.25
3rd	4	1280	HOT MIX ASPHALT, 402.378901 37.5 F9 BASE COURSE	Callanan Monticello	\$53.25
1st	5	1280	HOT MIX ASPHALT, 402.378901 37.5 F9 BASE COURSE	Morlyn Asphalt	\$51.00
2nd	5	1280	HOT MIX ASPHALT, 402.378901 37.5 F9 BASE COURSE	Eastern Materials Rt. 28	\$53.00
3rd	5	1280	HOT MIX ASPHALT, 402.378901 37.5 F9 BASE COURSE	Callanan Monticello	\$53.25
1st	1	1310	HOT MIX ASPHALT, 402.258901 25 F9 BINDER COURSE	Eastern Materials Rt. 28	\$54.00
2nd	1	1310	HOT MIX ASPHALT, 402.258901 25 F9 BINDER COURSE	Callanan East Kingston	\$53.50
3rd	1	1310	HOT MIX ASPHALT, 402.258901 25 F9 BINDER COURSE	Peckham	\$49.00
1st	2	1310	HOT MIX ASPHALT, 402.258901 25 F9 BINDER COURSE	Callanan East Kingston	\$53.50

2nd	2	1310	HOT MIX ASPHALT, 402.258901 25 F9 BINDER COURSE	Peckham	\$49.00
3rd	2	1310	HOT MIX ASPHALT, 402.258901 25 F9 BINDER COURSE	Morlyn Asphalt	\$52.00
1st	3	1310	HOT MIX ASPHALT, 402.258901 25 F9 BINDER COURSE	Callanan East Kingston	\$53.50
2nd	3	1310	HOT MIX ASPHALT, 402.258901 25 F9 BINDER COURSE	Peckham	\$49.00
3rd	3	1310	HOT MIX ASPHALT, 402.258901 25 F9 BINDER COURSE	Eastern Materials Rt. 28	\$54.00
1st	4	1310	HOT MIX ASPHALT, 402.258901 25 F9 BINDER COURSE	Morlyn Asphalt	\$52.00
2nd	4	1310	HOT MIX ASPHALT, 402.258901 25 F9 BINDER COURSE	Callanan East Kingston	\$53.50
3rd	4	1310	HOT MIX ASPHALT, 402.258901 25 F9 BINDER COURSE	Callanan Monticello	\$53.50
1st	5	1310	HOT MIX ASPHALT, 402.258901 25 F9 BINDER COURSE	Morlyn Asphalt	\$52.00
2nd	5	1310	HOT MIX ASPHALT, 402.258901 25 F9 BINDER COURSE	Eastern Materials Rt. 28	\$54.00
3rd	5	1310	HOT MIX ASPHALT, 402.258901 25 F9 BINDER COURSE	Callanan Monticello	\$53.50
1st	1	1340	HOT MIX ASPHALT, 402.198901 19 F9 BINDER COURSE	Eastern Materials Rt. 28	\$54.50
2nd	1	1340	HOT MIX ASPHALT, 402.198901 19 F9 BINDER COURSE	Callanan East Kingston	\$53.50
3rd	1	1340	HOT MIX ASPHALT, 402.198901 19 F9 BINDER COURSE	Peckham	\$49.00
1st	2	1340	HOT MIX ASPHALT, 402.198901 19 F9 BINDER COURSE	Callanan East Kingston	\$53.50
2nd	2	1340	HOT MIX ASPHALT, 402.198901 19 F9 BINDER COURSE	Peckham	\$49.00
3rd	2	1340	HOT MIX ASPHALT, 402.198901 19 F9 BINDER COURSE	Morlyn Asphalt	\$54.00
1st	3	1340	HOT MIX ASPHALT, 402.198901 19 F9 BINDER COURSE	Callanan East Kingston	\$53.50
2nd	3	1340	HOT MIX ASPHALT, 402.198901 19 F9 BINDER COURSE	Peckham	\$49.00

3rd	3	1340	HOT MIX ASPHALT, 402.198901 19 F9 BINDER COURSE	Eastern Materials Rt. 28	\$54.50
1st	4	1340	HOT MIX ASPHALT, 402.198901 19 F9 BINDER COURSE	Callanan East Kingston	\$53.50
2nd	4	1340	HOT MIX ASPHALT, 402.198901 19 F9 BINDER COURSE	Morlyn Asphalt	\$54.00
3rd	4	1340	HOT MIX ASPHALT, 402.198901 19 F9 BINDER COURSE	Callanan Monticello	\$53.50
1st	5	1340	HOT MIX ASPHALT, 402.198901 19 F9 BINDER COURSE	Morlyn Asphalt	\$54.00
2nd	5	1340	HOT MIX ASPHALT, 402.198901 19 F9 BINDER COURSE	Eastern Materials Rt. 28	\$54.50
3rd	5	1340	HOT MIX ASPHALT, 402.198901 19 F9 BINDER COURSE	Callanan Monticello	\$53.50
1st	1	1370	HOT MIX ASPHALT, 402.128201 12.5 F2 TOP COURSE	Eastern Materials Rt. 28	\$55.50
2nd	1	1370	HOT MIX ASPHALT, 402.128201 12.5 F2 TOP COURSE	Callanan East Kingston	\$54.75
3rd	1	1370	HOT MIX ASPHALT, 402.128201 12.5 F2 TOP COURSE	Peckham	\$54.00
1st	2	1370	HOT MIX ASPHALT, 402.128201 12.5 F2 TOP COURSE	Callanan East Kingston	\$54.75
2nd	2	1370	HOT MIX ASPHALT, 402.128201 12.5 F2 TOP COURSE	Peckham	\$54.00
3rd	2	1370	HOT MIX ASPHALT, 402.128201 12.5 F2 TOP COURSE	Morlyn Asphalt	\$55.00
1st	3	1370	HOT MIX ASPHALT, 402.128201 12.5 F2 TOP COURSE	Callanan East Kingston	\$54.75
2nd	3	1370	HOT MIX ASPHALT, 402.128201 12.5 F2 TOP COURSE	Peckham	\$54.00
3rd	3	1370	HOT MIX ASPHALT, 402.128201 12.5 F2 TOP COURSE	Eastern Materials Rt. 28	\$55.50
1st	4	1370	HOT MIX ASPHALT, 402.128201 12.5 F2 TOP COURSE	Callanan East Kingston	\$54.75
2nd	4	1370	HOT MIX ASPHALT, 402.128201 12.5 F2 TOP COURSE	Morlyn Asphalt	\$55.00
3rd	4	1370	HOT MIX ASPHALT, 402.128201 12.5 F2 TOP COURSE	Callanan Monticello	\$54.75

1st	5	1370	HOT MIX ASPHALT, 402.128201 12.5 F2 TOP COURSE	Morlyn Asphalt	\$55.00
2nd	5	1370	HOT MIX ASPHALT, 402.128201 12.5 F2 TOP COURSE	Eastern Materials Rt. 28	\$55.50
3rd	5	1370	HOT MIX ASPHALT, 402.128201 12.5 F2 TOP COURSE	Callanan Monticello	\$54.75
1st	1	1400	HOT MIX ASPHALT, 402.098201 9.5 F2 TOP COURSE	Eastern Materials Rt. 28	\$57.00
2nd	1	1400	HOT MIX ASPHALT, 402.098201 9.5 F2 TOP COURSE	Callanan East Kingston	\$57.75
3rd	1	1400	HOT MIX ASPHALT, 402.098201 9.5 F2 TOP COURSE	Peckham	\$57.75
1st	2	1400	HOT MIX ASPHALT, 402.098201 9.5 F2 TOP COURSE	Peckham	\$57.75
2nd	2	1400	HOT MIX ASPHALT, 402.098201 9.5 F2 TOP COURSE	Eastern Materials Rt. 28	\$57.00
3rd	2	1400	HOT MIX ASPHALT, 402.098201 9.5 F2 TOP COURSE	Callanan East Kingston	\$57.75
1st	3	1400	HOT MIX ASPHALT, 402.098201 9.5 F2 TOP COURSE	Callanan East Kingston	\$57.75
2nd	3	1400	HOT MIX ASPHALT, 402.098201 9.5 F2 TOP COURSE	Eastern Materials Rt. 28	\$57.00
3rd	3	1400	HOT MIX ASPHALT, 402.098201 9.5 F2 TOP COURSE	Peckham	\$57.75
1st	4	1400	HOT MIX ASPHALT, 402.098201 9.5 F2 TOP COURSE	Callanan East Kingston	\$57.75
2nd	4	1400	HOT MIX ASPHALT, 402.098201 9.5 F2 TOP COURSE	Morlyn Asphalt	\$59.00
3rd	4	1400	HOT MIX ASPHALT, 402.098201 9.5 F2 TOP COURSE	Callanan Monticello	\$57.75
1st	5	1400	HOT MIX ASPHALT, 402.098201 9.5 F2 TOP COURSE	Eastern Materials Rt. 28	\$57.00
2nd	5	1400	HOT MIX ASPHALT, 402.098201 9.5 F2 TOP COURSE	Morlyn Asphalt	\$59.00
3rd	5	1400	HOT MIX ASPHALT, 402.098201 9.5 F2 TOP COURSE	Callanan Monticello	\$57.75
1st	1	1410	MISCELLANEOUS PATCH	Eastern Materials Rt. 28	\$57.00
2nd	1	1410	MISCELLANEOUS PATCH	Callanan East Kingston	\$59.25
3rd	1	1410	MISCELLANEOUS PATCH	Peckham	\$64.00

1st	2	1410	MISCELLANEOUS PATCH	Callanan East Kingston	\$59.25
2nd	2	1410	MISCELLANEOUS PATCH	Eastern Materials Rt. 28	\$57.00
3rd	2	1410	MISCELLANEOUS PATCH	Morlyn Asphalt	\$60.00
1st	3	1410	MISCELLANEOUS PATCH	Callanan East Kingston	\$59.25
2nd	3	1410	MISCELLANEOUS PATCH	Eastern Materials Rt. 28	\$57.00
3rd	3	1410	MISCELLANEOUS PATCH	Peckham	\$64.00
1st	4	1410	MISCELLANEOUS PATCH	Callanan East Kingston	\$59.25
2nd	4	1410	MISCELLANEOUS PATCH	Eastern Materials Rt. 28	\$57.00
3rd	4	1410	MISCELLANEOUS PATCH	Morlyn Asphalt	\$60.00
1st	5	1410	MISCELLANEOUS PATCH	Eastern Materials Rt. 28	\$57.00
2nd	5	1410	MISCELLANEOUS PATCH	Morlyn Asphalt	\$60.00
3rd	5	1410	MISCELLANEOUS PATCH	Callanan Monticello	\$59.25

ROAD MATERIALS BID SHEETS - DELIVERED PRICING

B

BID #RFB-UC20-001

BIDDER: _____

TERM 4/1/2020- 3/31/2021

STOCKYARD LOCATION: _____

SECTION B - PRICING DELIVERED BY THE VENDOR TO THE SECTION LISTED

<u>LOW</u>	<u>ITEM ID#</u>	<u>DESCRIPTION</u>	<u>SECTION</u>	<u>PRICE BID</u>	<u>VENDOR</u>	<u>UNIT</u>
1st	101	REDI-MIX CONCRETE CLASS A	1	\$110.00	Cranesville Block	PER YARD
2nd	101	REDI-MIX CONCRETE CLASS A	1	No Award	No Award	PER YARD
3rd	101	REDI-MIX CONCRETE CLASS A	1	No Award	No Award	PER YARD
1st	102	REDI-MIX CONCRETE CLASS A	2	\$111.00	Cranesville Block	PER YARD
2nd	102	REDI-MIX CONCRETE CLASS A	2	\$129.00	E. Tetz	PER YARD
3rd	102	REDI-MIX CONCRETE CLASS A	2	No Award	No Award	PER YARD
1st	103	REDI-MIX CONCRETE CLASS A	3	\$108.00	Cranesville Block	PER YARD
2nd	103	REDI-MIX CONCRETE CLASS A	3	No Award	No Award	PER YARD
3rd	103	REDI-MIX CONCRETE CLASS A	3	No Award	No Award	PER YARD
1st	104	REDI-MIX CONCRETE CLASS A	4	\$111.00	Cranesville Block	PER YARD
2nd	104	REDI-MIX CONCRETE CLASS A	4	No Award	No Award	PER YARD
3rd	104	REDI-MIX CONCRETE CLASS A	4	No Award	No Award	PER YARD
1st	105	REDI-MIX CONCRETE CLASS A	5	\$122.00	Cranesville Block	PER YARD
2nd	105	REDI-MIX CONCRETE CLASS A	5	No Award	No Award	PER YARD
3rd	105	REDI-MIX CONCRETE CLASS A	5	No Award	No Award	PER YARD
1st	131	REDI-MIX CONCRETE CLASS E	1	\$112.00	Cranesville Block	PER YARD
2nd	131	REDI-MIX CONCRETE CLASS E	1	No Award	No Award	PER YARD
3rd	131	REDI-MIX CONCRETE CLASS E	1	No Award	No Award	PER YARD
1st	132	REDI-MIX CONCRETE CLASS E	2	\$114.00	Cranesville Block	PER YARD
2nd	132	REDI-MIX CONCRETE CLASS E	2	No Award	No Award	PER YARD
3rd	132	REDI-MIX CONCRETE CLASS E	2	No Award	No Award	PER YARD
1st	133	REDI-MIX CONCRETE CLASS E	3	\$110.00	Cranesville Block	PER YARD
2nd	133	REDI-MIX CONCRETE CLASS E	3	No Award	No Award	PER YARD
3rd	133	REDI-MIX CONCRETE CLASS E	3	No Award	No Award	PER YARD
1st	134	REDI-MIX CONCRETE CLASS E	4	\$114.00	Cranesville Block	PER YARD
2nd	134	REDI-MIX CONCRETE CLASS E	4	No Award	No Award	PER YARD
3rd	134	REDI-MIX CONCRETE CLASS E	4	No Award	No Award	PER YARD
1st	135	REDI-MIX CONCRETE CLASS E	5	\$124.00	Cranesville Block	PER YARD
2nd	135	REDI-MIX CONCRETE CLASS E	5	No Award	No Award	PER YARD
3rd	135	REDI-MIX CONCRETE CLASS E	5	No Award	No Award	PER YARD
	161	ROCK SALT- FULL TRUCK, 22 TON MIN.	1	\$85.14	Morton Salt	PER TON
	162	ROCK SALT- FULL TRUCK, 22 TON MIN.	2	\$85.52	Morton Salt	PER TON

163	ROCK SALT- FULL TRUCK, 22 TON MIN.	3	\$81.08	Morton Salt	PER TON
164	ROCK SALT- FULL TRUCK, 22 TON MIN.	4	\$84.88	Morton Salt	PER TON
165	ROCK SALT- FULL TRUCK, 22 TON MIN.	5	\$90.83	Morton Salt	PER TON
191	#1 STONE - WASHED	1	\$21.50	Callanan East Kingston	PER TON
192	#1 STONE - WASHED	2	\$21.40	Callanan East Kingston	PER TON
193	#1 STONE - WASHED	3	\$19.65	Peckham	PER TON
194	#1 STONE - WASHED	4	\$20.55	Callanan Monticello	PER TON
195	#1 STONE - WASHED	5	\$21.30	Callanan Monticello	PER TON
281	#1 ST STONE - WASHED	1	\$23.90	Peckham	PER TON
282	#1 ST STONE - WASHED	2	\$24.20	Callanan Monticello	PER TON
283	#1 ST STONE - WASHED	3	\$20.40	Peckham	PER TON
284	#1 ST STONE - WASHED	4	\$21.65	Callanan Monticello	PER TON
285	#1 ST STONE - WASHED	5	\$22.40	Callanan Monticello	PER TON
311	#1A STONE - WASHED	1	\$27.80	Peckham	PER TON
312	#1A STONE - WASHED	2	\$30.30	Peckham	PER TON
313	#1A STONE - WASHED	3	\$24.30	Peckham	PER TON
314	#1A STONE - WASHED	4	\$30.05	Callanan East Kingston	PER TON
315	#1A STONE - WASHED	5	\$31.30	Callanan Monticello	PER TON
341	#1 & #2 STONE - WASHED	1	\$20.35	Callanan East Kingston	PER TON
342	#1 & #2 STONE - WASHED	2	\$20.25	Callanan East Kingston	PER TON
343	#1 & #2 STONE - WASHED	3	\$18.55	Callanan East Kingston	PER TON
344	#1 & #2 STONE - WASHED	4	\$19.90	Callanan East Kingston	PER TON
345	#1 & #2 STONE - WASHED	5	\$21.20	Callanan Monticello	PER TON
371	#2 STONE	1	\$16.50	Mombaccus	PER TON
372	#2 STONE	2	\$16.50	Mombaccus	PER TON
373	#2 STONE	3	\$16.50	Mombaccus	PER TON
374	#2 STONE	4	\$17.00	Mombaccus	PER TON
375	#2 STONE	5	\$19.00	Mombaccus	PER TON
381	#3A STONE (MIX OF #2 & #3)	1	\$20.00	Eastern Materials	PER TON
382	#3A STONE (MIX OF #2 & #3)	2	\$20.00	Eastern Materials	PER TON
383	#3A STONE (MIX OF #2 & #3)	3	\$18.55	Callanan East Kingston	PER TON
384	#3A STONE (MIX OF #2 & #3)	4	\$19.90	Callanan East Kingston	PER TON
385	#3A STONE (MIX OF #2 & #3)	5	\$21.00	Eastern Materials	PER TON
401	#3 STONE	1	\$16.75	Mombaccus	PER TON
402	#3 STONE	2	\$16.50	Mombaccus	PER TON
403	#3 STONE	3	\$16.50	Mombaccus	PER TON
404	#3 STONE	4	\$17.00	Mombaccus	PER TON
405	#3 STONE	5	\$19.30	Mombaccus	PER TON

411	#4A STONE	1	\$20.00	Mombaccus	PER TON
412	#4A STONE	2	\$20.00	Mombaccus	PER TON
413	#4A STONE	3	\$20.00	Mombaccus	PER TON
414	#4A STONE	4	\$21.00	Mombaccus	PER TON
415	#4A STONE	5	\$21.00	Eastern Materials	PER TON
421	#4 STONE	1	\$20.00	Mombaccus	PER TON
422	#4 STONE	2	\$20.00	Mombaccus	PER TON
423	#4 STONE	3	\$20.00	Mombaccus	PER TON
424	#4 STONE	4	\$21.00	Mombaccus	PER TON
425	#4 STONE	5	\$21.00	Eastern Materials	PER TON
431	ITEM #4	1	\$14.80	Mombaccus	PER TON
432	ITEM #4	2	\$15.00	Mombaccus	PER TON
433	ITEM #4	3	\$14.50	Mombaccus	PER TON
434	ITEM #4	4	\$16.00	Mombaccus	PER TON
435	ITEM #4	5	\$18.00	Mombaccus	PER TON
451	FINE STONE	1	\$19.00	Mombaccus	PER TON
452	FINE STONE	2	\$20.00	Mombaccus	PER TON
453	FINE STONE	3	\$17.75	Mombaccus	PER TON
454	FINE STONE	4	\$18.00	Mombaccus	PER TON
455	FINE STONE	5	\$22.00	Mombaccus	PER TON
461	LIGHT STONE	1	\$19.00	Mombaccus	PER TON
462	LIGHT STONE	2	\$20.00	Mombaccus	PER TON
463	LIGHT STONE	3	\$17.75	Mombaccus	PER TON
464	LIGHT STONE	4	\$18.00	Mombaccus	PER TON
465	LIGHT STONE	5	\$22.00	Mombaccus	PER TON
491	MEDIUM STONE	1	\$19.50	Mombaccus	PER TON
492	MEDIUM STONE	2	\$24.00	Mombaccus	PER TON
493	MEDIUM STONE	3	\$23.35	Peckham	PER TON
494	MEDIUM STONE	4	\$23.40	Mombaccus	PER TON
495	MEDIUM STONE	5	\$25.00	Mombaccus	PER TON
521	HEAVY STONE	1	\$24.50	Mombaccus	PER TON
522	HEAVY STONE	2	\$24.50	Mombaccus	PER TON
523	HEAVY STONE	3	\$23.00	Mombaccus	PER TON
524	HEAVY STONE	4	\$23.00	Mombaccus	PER TON
525	HEAVY STONE	5	\$27.00	Mombaccus	PER TON
551	SELECT FILL	1	\$14.50	Mombaccus	PER TON
552	SELECT FILL	2	\$14.75	Mombaccus	PER TON
553	SELECT FILL	3	\$14.00	Mombaccus	PER TON

554	SELECT FILL	4	\$13.50	Mombaccus	PER TON
<u>555</u>	SELECT FILL	<u>5</u>	\$16.55	Callanan Monticello	PER TON
581	SELECT GRANULAR FILL	1	\$14.75	Mombaccus	PER TON
582	SELECT GRANULAR FILL	2	\$14.00	Mombaccus	PER TON
583	SELECT GRANULAR FILL	3	\$13.75	Mombaccus	PER TON
584	SELECT GRANULAR FILL	4	\$13.25	Mombaccus	PER TON
<u>585</u>	SELECT GRANULAR FILL	<u>5</u>	\$16.55	Callanan Monticello	PER TON
1211	RETANGULAR QUARRIED BOULDERS	1	\$29.60	Peckham	PER TON
1212	RETANGULAR QUARRIED BOULDERS	2	\$32.00	Mombaccus	PER TON
1213	RETANGULAR QUARRIED BOULDERS	3	\$23.00	Mombaccus	PER TON
1214	RETANGULAR QUARRIED BOULDERS	4	\$28.00	Mombaccus	PER TON
<u>1215</u>	RETANGULAR QUARRIED BOULDERS	<u>5</u>	\$37.30	Callanan Monticello	PER TON
791	TOPSOIL	1	\$40.00	Eastern Materials	PER TON
792	TOPSOIL	2	\$40.00	Eastern Materials	PER TON
793	TOPSOIL	3	\$37.00	Mombaccus	PER TON
794	TOPSOIL	4	\$37.00	Mombaccus	PER TON
<u>795</u>	TOPSOIL	<u>5</u>	\$42.00	Mombaccus	PER TON
801	ABRASIVE SAND, WASHED	1	\$20.00	Red Wing Properties	PER TON
802	ABRASIVE SAND, WASHED	2	\$20.00	Red Wing Properties	PER TON
803	ABRASIVE SAND, WASHED	3	\$17.20	A. Colarusso	PER TON
804	ABRASIVE SAND, WASHED	4	\$20.00	Red Wing Properties	PER TON
<u>805</u>	ABRASIVE SAND, WASHED	<u>5</u>	\$29.35	A. Colarusso	PER TON
701	ABRASIVE SAND, SCREENED	1	\$17.00	Mombaccus	PER TON
702	ABRASIVE SAND, SCREENED	2	\$15.75	Mombaccus	PER TON
703	ABRASIVE SAND, SCREENED	3	\$15.50	Mombaccus	PER TON
704	ABRASIVE SAND, SCREENED	4	\$13.25	Mombaccus	PER TON
<u>705</u>	ABRASIVE SAND, SCREENED	<u>5</u>	\$20.00	Mombaccus	PER TON
1241	ABRASIVE SCREENINGS, WASHED	1	\$19.70	Callanan South Bethlehem	PER TON
1242	ABRASIVE SCREENINGS, WASHED	2	\$20.00	Eastern Materials	PER TON
1243	ABRASIVE SCREENINGS, WASHED	3	\$16.20	Callanan South Bethlehem	PER TON
1244	ABRASIVE SCREENINGS, WASHED	4	\$19.70	Callanan South Bethlehem	PER TON
<u>1245</u>	ABRASIVE SCREENINGS, WASHED	<u>5</u>	\$21.25	Callanan Monticello	PER TON
761	ABRASIVE SCREENINGS, SCREENED	1	\$17.00	Mombaccus	PER TON
762	ABRASIVE SCREENINGS, SCREENED	2	\$15.75	Mombaccus	PER TON
763	ABRASIVE SCREENINGS, SCREENED	3	\$15.50	Mombaccus	PER TON
764	ABRASIVE SCREENINGS, SCREENED	4	\$13.25	Mombaccus	PER TON
<u>765</u>	ABRASIVE SCREENINGS, SCREENED	<u>5</u>	\$20.00	Mombaccus	PER TON
811	ABRASIVE STONE DUST	1	\$18.00	Eastern Materials	PER TON

812	ABRASIVE STONE DUST	2	\$16.60	Callanan Monticello	PER TON
813	ABRASIVE STONE DUST	3	\$16.60	Callanan Monticello	PER TON
814	ABRASIVE STONE DUST	4	\$14.05	Callanan Monticello	PER TON
815	ABRASIVE STONE DUST	5	\$14.80	Callanan Monticello	PER TON
821	ABRASIVE SAND, SCREENED, MIXED W/COUNTY SUPPLIED SALT	1	\$17.80	Mombaccus	PER TON
822	ABRASIVE SAND, SCREENED, MIXED W/COUNTY SUPPLIED SALT	2	\$18.20	Mombaccus	PER TON
823	ABRASIVE SAND, SCREENED, MIXED W/COUNTY SUPPLIED SALT	3	\$17.70	Mombaccus	PER TON
824	ABRASIVE SAND, SCREENED, MIXED W/COUNTY SUPPLIED SALT	4	\$20.00	Mombaccus	PER TON
825	ABRASIVE SAND, SCREENED, MIXED W/COUNTY SUPPLIED SALT	5	\$22.40	Mombaccus	PER TON
881	ABRASIVE SCREENINGS, SCREENED, MIXED W/COUNTY SUPPLIED SALT	1	\$17.80	Mombaccus	PER TON
882	ABRASIVE SCREENINGS, SCREENED, MIXED W/COUNTY SUPPLIED SALT	2	\$18.20	Mombaccus	PER TON
883	ABRASIVE SCREENINGS, SCREENED, MIXED W/COUNTY SUPPLIED SALT	3	\$17.70	Mombaccus	PER TON
884	ABRASIVE SCREENINGS, SCREENED, MIXED W/COUNTY SUPPLIED SALT	4	\$20.00	Mombaccus	PER TON
885	ABRASIVE SCREENINGS, SCREENED, MIXED W/COUNTY SUPPLIED SALT	5	\$22.40	Mombaccus	PER TON

NOTE: All bidders must have Scales that have been Certified by the NYS DOT and provide accurate trip tickets indicating the exact weight that is being invoiced. Invoicing by the yard is not acceptable except when invoicing Redi-Mix concrete.